

Max length of units are 1400mm. Longer units will be manufactured in manageable pieces to suit.

A keystone can also be clipped over to add extra detail. Please see following page.

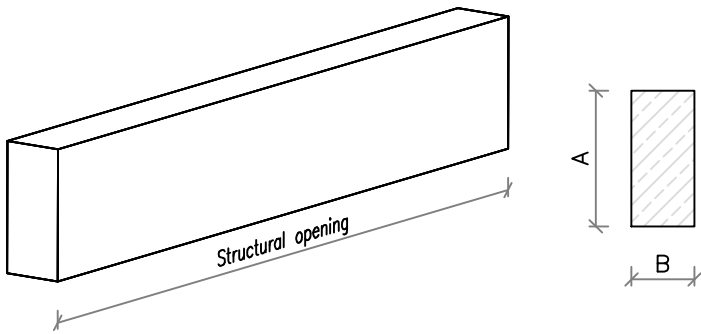

Code	Height (A)	Depth (B)	Weight (kg/m)
H2	140	100	29
H2R	140	120	35
H2-Imp	156	100	33
H3	215	100	45
H3R	215	120	54
H3-Imp	239	100	50
H4	290	100	61
H4R	290	120	73
H4-Imp	322	100	68

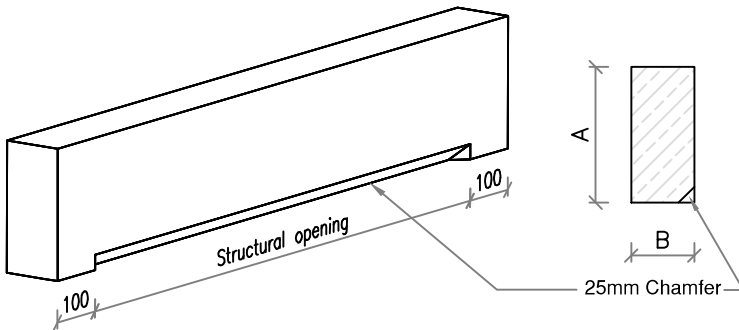

Code	Height (A)	Depth (B)	Weight (kg/m)
H2F	140	100	29
H2FR	140	120	35
H2F-Imp	156	100	33
H3F	215	100	45
H3FR	215	120	54
H3F-Imp	239	100	50
H4F	290	100	61
H4FR	290	120	73
H4F-Imp	322	100	68

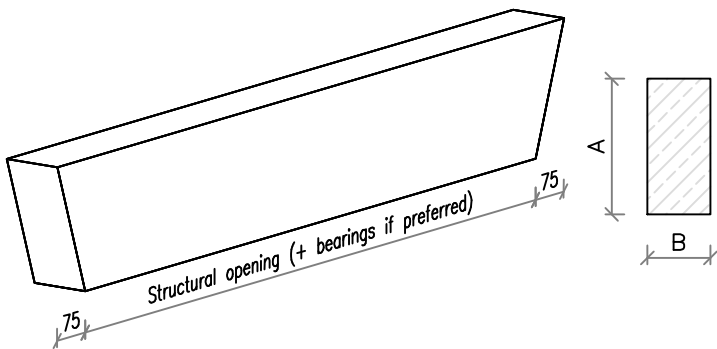

Code	Height (A)	Depth (B)	Weight (kg/m)
H2S	140	100	25
H2SR	140	120	33
H2S-Imp	156	100	30
H3S	215	100	48
H3SR	215	120	50
H3S-Imp	239	100	53
H4S	290	100	64
H3SR	290	120	68
H4S-Imp	322	100	63

GH3 Style

(Georgian Style)

